

Grupa A

Imię i nazwisko

Klasa

Poziom podstawowy

SŁUCHANIE

ZADANIE I.

Usłyszysz dwukrotnie krótkie teksty. Przeczytaj poniższe pytania (1-5) i wybierz właściwe odpowiedzi. Zakreśl literę A, B lub C.

Przykład:

What 's Fiona's favourite season?

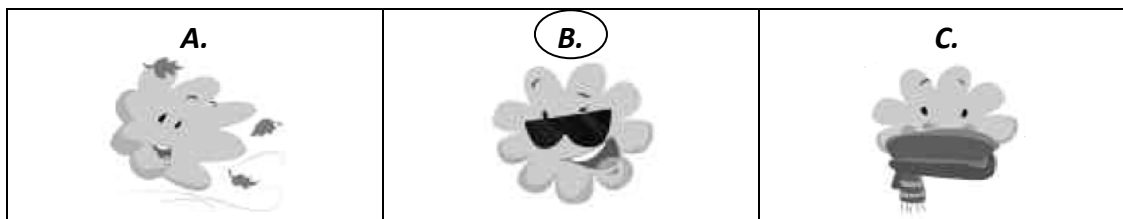

1. What are Bob and Tina doing?

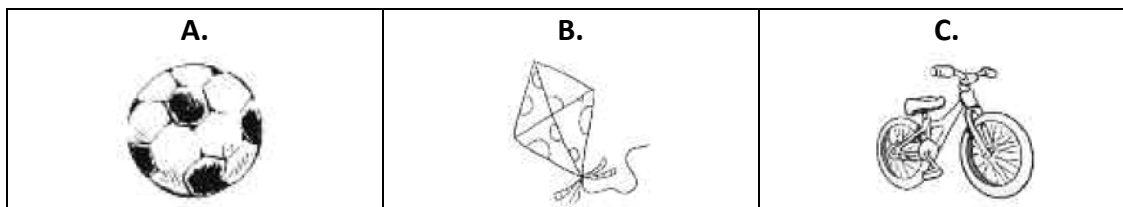

2. What's Judy wearing?

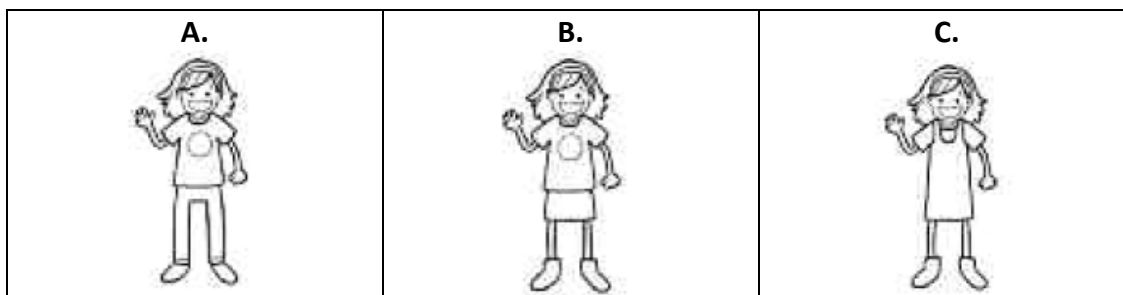

3. What's Mum doing?

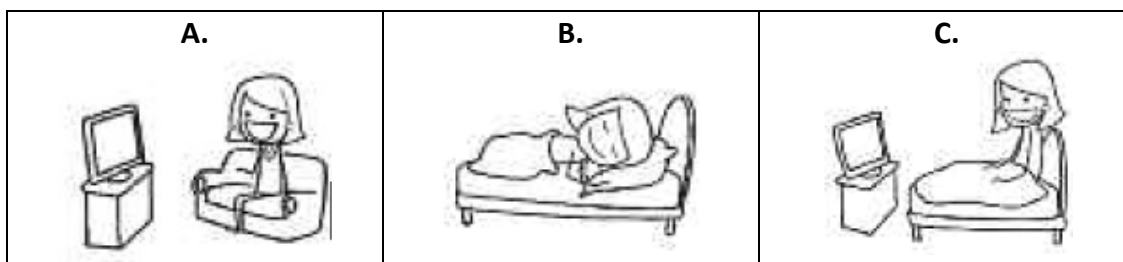

4. What are Flora's favourite toys?

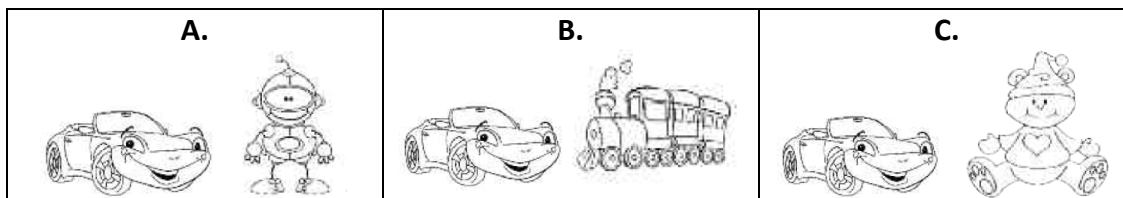

5. What does Cecil have in his lunchbox?

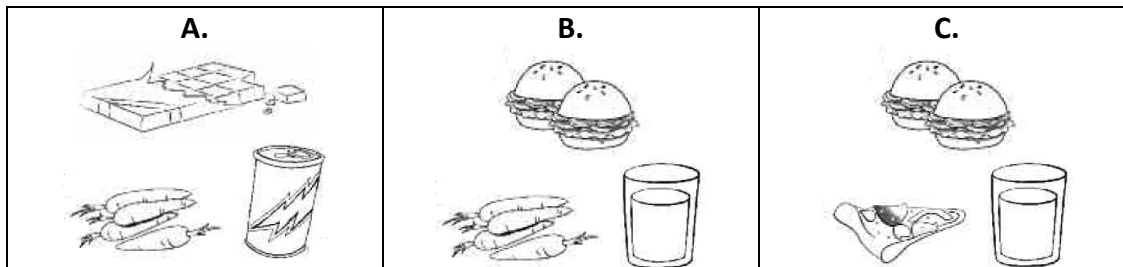

..... / 10 pkt.

CZYTANIE

ZADANIE II.

Przeczytaj uważnie tekst. Następnie przeczytaj 5 zdań pod tekstem. Wskaż, które zdania są prawdziwe (P), a które fałszywe (F). Wpisz znak (✓) w odpowiedniej kolumnie.



Phineas Flynn lives in the USA. Ferb is his brother.

Phineas is intelligent and has got many talents. He can sing and he can play many musical instruments: the bass, the guitar, the piano, the tambourine, and the drums.

Phineas has got short, red hair. His head is a triangle-shaped. He has got a big nose and big, blue eyes.

Phineas wears a yellow T-shirt with orange stripes, blue shorts and blue shoes.

Przykład:

	P	F
<i>Phineas is a girl.</i>		✓

	P	F
1. Phineas hasn't got a brother.		
2. Phineas can play the drums.		
3. He has got long, red hair.		
4. He has got blue eyes.		
5. He wears a yellow T-shirt, blue shorts and pink shoes.		

..... / 10 pkt.

KOMUNIKACJA

ZADANIE III.

Przeczytaj minidialogi. Wybierz spośród podanych odpowiedzi brakującą wypowiedź jednej z osób. Zakreśl literę A lub B.

Przykład:

X: Hello!

Y: A. Hi!
 B. Wow!

- | | |
|--|---|
| 1. X: Hi Kelly. This is Bob.
Y: <input type="radio"/> A. Yes, it is.
<input type="radio"/> B. Hello, Bob. | 6. X: What's the weather like?
Y: <input type="radio"/> A. It's warm and sunny.
<input type="radio"/> B. It's very funny! |
| 2. X: Have you got a brother?
Y: <input type="radio"/> A. Yes, I have.
<input type="radio"/> B. Yes, I do. | 7. X: How old are you?
Y: <input type="radio"/> A. I'm nine.
<input type="radio"/> B. Happy Birthday! |
| 3. X: What's this?
Y: <input type="radio"/> A. It's a pen.
<input type="radio"/> B. It's my sister. | 8. X: Do you like burgers?
Y: <input type="radio"/> A. No, he doesn't.
<input type="radio"/> B. No, yuk! |
| 4. X: Can I have some chips, please?
Y: <input type="radio"/> A. Thank you.
<input type="radio"/> B. Here you are. | 9. X: Is there any pasta?
Y: <input type="radio"/> A. No, sorry.
<input type="radio"/> B. No, there is. |
| 5. X: Whose is this bike?
Y: <input type="radio"/> A. It's Patrick's.
<input type="radio"/> B. It's Patrick. | 10. X: What's your favourite food?
Y: <input type="radio"/> A. Yes, it is.
<input type="radio"/> B. Sausages! |

..... / 10 pkt.

SŁOWNICTWO

ZADANIE IV.

Przyjrzyj się obrazkom i podpisom pod nimi. Wybierz ten podpis, który pasuje do obrazka. Zakreśl literę A lub B.

Przykład:



1.

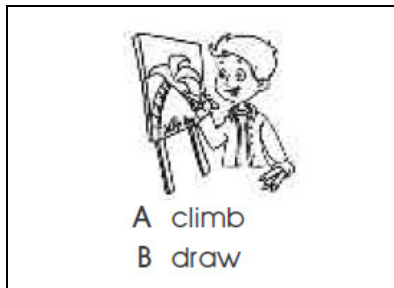

2.

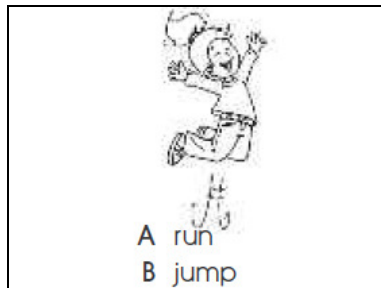

3.

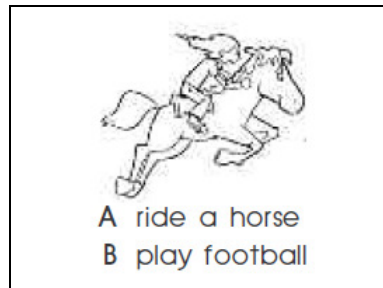

4.

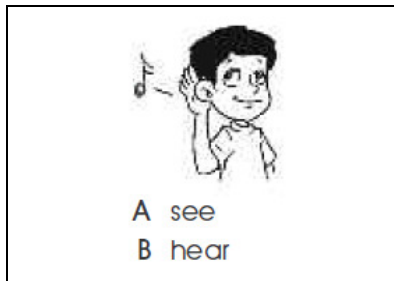

5.

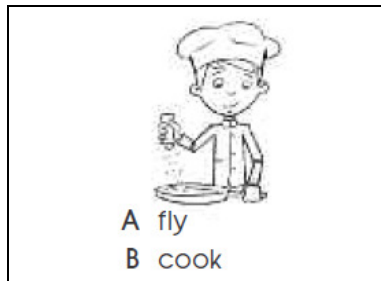

..... / 5 pkt.

ZADANIE V.

Uzupełnij brakujące litery w podpisach pod obrazkami.

Przykład:



1.



2.

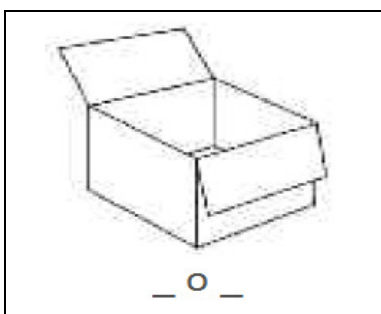

3.

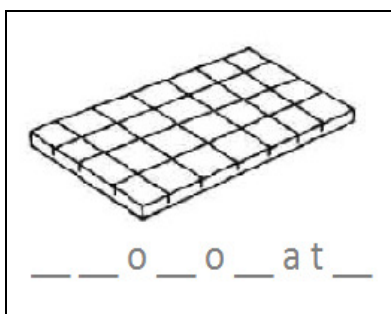

4.

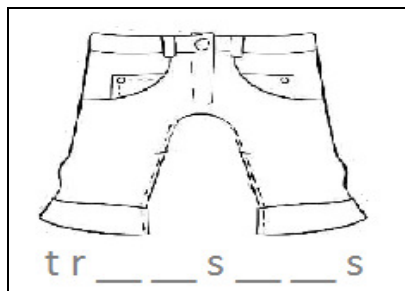

5.



..... / 10 pkt.

GRAMATYKA

ZADANIE VI.

Ułóż podane wyrazy w takiej kolejności, aby powstały poprawne zdania.

Przykład:

football.

I

play

don't

I don't play football.

1.

late.

He

bed

to

goes

2.

dinner

I

o'clock.

at

have

eight

3.

do

What time

have

you

lunch?

4.

My

planes.

brother

flies

5.

aren't

They

to

music.

listening

6.

drinking

aren't

milk.

We

7.

watching

Are

TV?

you

8.

playing

are

football

park.

They

the

in

9.

the

in

cooking

kitchen.

is

She

10.

umbrella

an

under

There

chair.

the

is

..... / 20 pkt.

Poziom ponadpodstawowy

ZADANIE VII.

Odpowiedz pełnymi zdaniami na poniższe pytania.

1. How old are you?

.....

2. Have you got a sister?

.....

3. What can you do?

.....

4. What have you got in your schoolbag? (wymień 3 rzeczy)

.....

5. What are you like? (wymień 2-3 cechy)

.....

..... / 15 pkt.

ZADANIE VIII.

Opisz postać na ilustracji.



My monster

.....
.....
.....
.....
.....
.....
.....
.....
.....
.....

..... / 20 pkt.

RAZEM: / 100 pkt.